

# CLEAN STEAM PRODUCTS

Steam-in-place sterilization (SIP) systems for vessels and associated piping are highly engineered systems. There are several different arrangements used by the Biotech Industry to purge air, heat-up the vessel and maintain a steam temperature of 121°C for a minimum of 15 minutes. Typically clean steam is introduced to the top of the vessel and exits through feed lines, vent lines and drain lines. Air, steam and condensate typically flow through a three-way valve (Piping Diagram) located at the remote end of each pipeline. During this heat up stage the peak condensate loads shown in the table below are encountered. When the vessel is heated to 95°C, the air is considered to be sufficiently purged and the three-way valve switches over to the Nicholson Model CME “CoMBo” steam trap. Once the temperature reaches the desired 121°C, tank heat losses are minimal and the steady condensate maintenance load shown in the table below are maintained.

## PEAK CONDENSATE LOADS

Tank Volume (Liter)	Peak Condensate heat-up Load lb/hr (kg/hr)	Condensate Maintenance Load lb/hr (kg/hr)
40000	2500 (1134)	27 (12)
15000	1250 (567)	14 (6)
7200	400 (181)	7 (3)
3000	300 (136)	5 (2)
1500	200 (91)	3 (1.4)
600	100 (45)	2 (.9)
100	30 (14)	1 (.4)
20	15 (7)	0.5 (.2)

The high capacity of the CME makes it an excellent choice when a 3-way valve is not utilized. It can be used to pass Clean-In-Place Return (CIPR) as shown in the Piping Diagrams. The Nicholson CME can pass 3608 #/Hr (1636 kg/hr) of 80°C condensate at 20 psi (1.4 bar) which exceeds the design peak condensate load of 2500#/Hr (1134 kg/hr) for all tank volumes shown above. The requirement to use multiple steam traps or a 3-way valve on the bottom of a sterilization tank depends on the time required to purge the air and condensate during the air purge cycle. The ball valve allows a faster purging of the condensate, but increases the sterilization time since it slows pressure build-up if steam is vented.

## PIPING DIAGRAMS

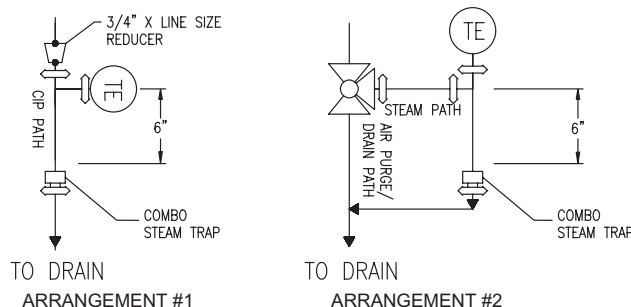

The operating cycle of a thermostatic steam trap is based on the difference in temperature between the condensate and steam. This difference in temperature is known as “sub-cool”, and is an indicator of the sensitivity of the trap. Nicholson’s model CDS 204, installed with the optional –B bellows, is the most sensitive trap in the market with a 1°C (2-3°F) sub-cool. This means that SIP system temperatures can be set lower because control limits are tighter as shown in the graph below. This lower temperature reduces rousing and extends the life of components.

## CoMBo TEMPERATURE CONTROL

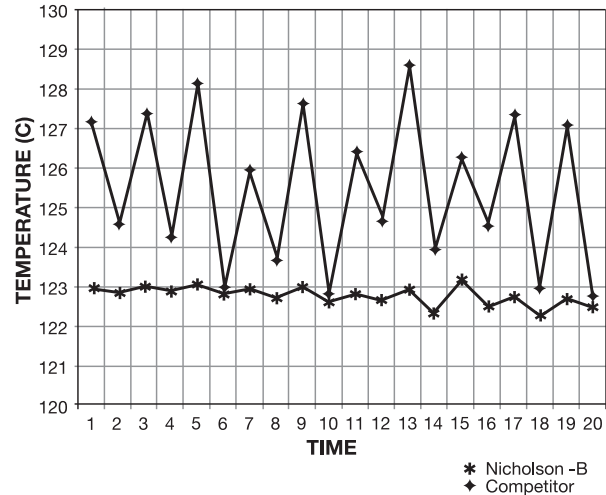

Extensive testing with the CME CoMBo has shown that the condensate backup varies with the steam pressure and condensate load as shown in the chart below. High sensitivity in combination with the industry’s highest capacity means a minimum condensate leg is required above the trap to achieve the required cooling. The CoMBo maintains condensate below the temperature thermocouple for loads ranging from 1 to 27 lb/hr (0.4-12 kg/hr) which are encountered during SIP maintenance of vessels ranging from 20 liters to 40,000 liters respectively.

## CoMBo BACKUP TESTING

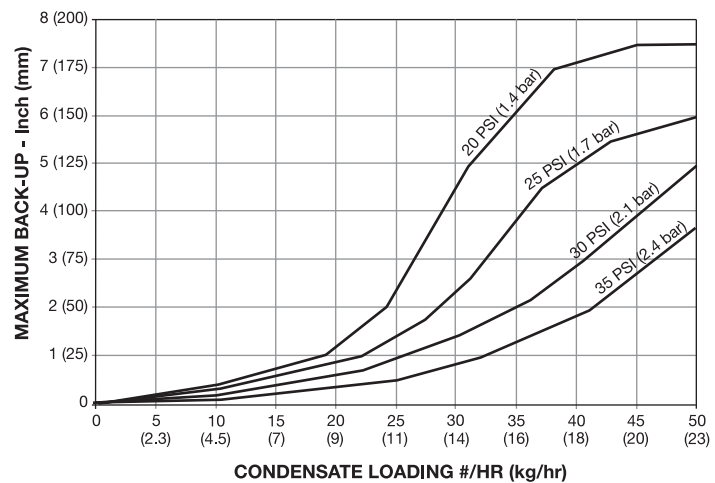

2



**CONDENSATE MEASURING ELBOW**

**APPLICATIONS**

- CIP/SIP System Condensate Drainage
- Sterilization of Process Vessels
- Culinary Steam
- Humidifiers
- WFI System Sterilization
- Fermenter Sterilization

**OPTIONS**

- MP - Mechanical Polish to 10 μ in. Ra
- EP - Electropolish
- SLR - SLR Orifice
- Tef-Steel, PTFE, Teflon®, E.P.D.M., USP Class VI & other gasket materials also available
- Horizontal or vertical inlet flow
- Horizontal or vertical well
- Horizontal or vertical outlet flow

**APPLICABLE CODES**

- ASME BPE
- Canadian Registration # 0E0591.9

**ORDERING CODE**

- CME-A - Direct Immersion RTD

Trap Style	Orifice	Outlet Connection	Gasket	Ends and Finish	Well	Bellows
CME	1	6	V	6	NO	B
CME - CoMBo	1 - 204 (5/16")	6 - 1/2" - 3/4" 7 - 1" - 1 1/2"	V - Viton E - EPDM P - PTFE S - Silicone	6 - Tri Clamp, SF1 (MP 20 Ra) 7 - Tri Clamp, SF4 (EP 15 Ra)	W2 - 2.5" Well NO - None	B - Sensitive bellows (Std.)

**OPERATION**

Thermal actuator is filled at its free length with a liquid having a lower boiling point than water. On start-up, valve is normally open to discharge air, non-condensibles and condensate. When steam enters trap, thermal actuator fill vaporizes to a pressure higher than line pressure. This forces valve into seat orifice to prevent any further flow. As

condensate collects, it takes heat from the actuator, lowering internal pressure. Line pressure will then compress thermal actuator to open valve and discharge condensate. Valve opening automatically adjusts to load conditions from minimum on very light loads to full lift at maximum load. Sensitivity of bellows maintains condensate below thermal probe connection.

# CoMBo CONDENSATE MEASURING ELBOW THERMOSTATIC STEAM TRAP

Pressures to 40 PSIG (2.7 barg)  
Temperatures to 292°F (144°C)

**Sensitivity** – The –B bellows has been designed to achieve a 1°C (2-3°F) sub-cool. This is the most sensitive trap in the market place. It maintains backup of condensate below 6" (150mm) for SIP maintenance of vessels sized 40,000 liters and below.

**High Capacity** – These traps have 30-50% higher capacities than any competitor. This means they can often handle the peak condensate load encountered during vessel heat-up without requiring by-pass through a three-way valve.

**Long Life** – The single moving part is a multi-plate bellows made of 316L Stainless Steel. The bellows have been tested to exceed 40,000,000 cycles.

**Industry Standard Food Grade Gasket** – One gasket fits all Nicholson Sanitary Steam Traps. White Viton food grade gasket offers superior performance for higher pressure steam applications.

**Water Hammer Protection** – Impingement plate protects the bellows and valve from hydraulic shock. This design allows self-centering alignment for superior valve-to-orifice sealing.

**Modulating Flow Dynamics** – Nicholson Sanitary Steam Traps use conical valves for better flow dynamics, consistent system temperature and pressure and longer life than ball bearing valves.

**Self Draining** – Completely free draining with the steepest interior surfaces prevents puddling.

**Air Venting** – Thermostatic element allows for superior air venting and faster system startup.

**Cost Efficient** – Eliminates clamp on top of CDS

**Simplified Validation** – Only one unit to validate, complete with all MTRs.

NOTE: Please specify if Material Test Reports (MTR) or Certificates of Conformance (COC) are required.

# CoMBo CONDENSATE MEASURING ELBOW THERMOSTATIC STEAM TRAP

## SPECIFICATION

Steam trap shall be of balanced pressure design with 316L welded bellows capable of releasing condensate within 1°C (2-3°F) of saturated pressure. All other interior wetted components shall be of 316L stainless. It shall have interior body finish of at least 20 µ in. (0.5 µm) Ra and exterior body finish of at least 32 µ in. (0.75µm) Ra. Trap shall utilize hygienic body clamp allowing disassembly for inspection or cleaning and be entirely self draining. Trap end connections shall be standard hygienic clamp. Thermostatic actuator shall employ a conical valve lapped to the seat. Traps shall have SLR orifice where drainage at saturated temperatures is required. Traps shall be guaranteed against defects for 3 years. Trap shall maintain condensate below the temperature thermocouple for loads ranging from 1 to 27 lb/hr (0.4 to 12 kg/hr) which are encountered during SIP maintenance of vessels ranging from 20 liters to 40,000 liters respectively.

### MAXIMUM OPERATING CONDITIONS

PMO: Max. Operating Pressure	40 psig (2.7 barg)
TMO: Max. Operating Temperature	292°F (144°C)
PMA: Max. Allowable Pressure	150 psig (10.3 barg)
TMA: Max. Allowable Temperature	366°F (186°C)

### MATERIALS OF CONSTRUCTION

Part #	Part Name	Material
1	Condensate Elbow	ASME BPE 316L
2	Actuator Nut	316L
3	Body Gasket	Viton 3227
4	-B Bellows	316L
5	Body – Outlet	A276 316L
6	Valve	316L
7	Body Clamp	304
8	Impingement Plate	316L
9	Well	316L
10	Well Gasket	Viton 3227
11	Well Clamp	304

### BODY SURFACE FINISH

Internal <20 µ in. (0.5 µm) Ra SFCI. External <32 µ in. (0.75 µm) Ra. Optional mechanical polishing to 10 µ in. (0.25 µm) Ra and/or electropolish SFC4

### GASKET APPROVALS

FDA CFR Title 21 Part 177, USDA, USP Class VI, 3A Sanitary Standard, NSF

### SERVICE NOTES

Trap is supplied with the -B Bellows to maintain condensate below the thermal probe. CME-W25 is designed to be self-draining with a horizontal inlet and vertical downward discharge.

MAXIMUM CAPACITY - lbs/hr (kg/hr)

Condensate Temperature	Orifice Inches	Differential PSIG (bar)							
		5	10	15	20	25	30	35	40
80°C Water	5/16	1804 (819)	2551 (1158)	3121 (1417)	3608 (1638)	4015 (1823)	4419 (2006)	4763 (2162)	5030 (2284)
		1520 (690)	1671 (759)	1791 (813)	1869 (849)	1983 (900)	2128 (966)	2212 (1004)	2301 (1045)
5°C Subcool	5/16	682 (310)	775 (352)	835 (379)	861 (391)	915 (415)	975 (443)	995 (452)	1109 (503)
1°C Subcool									

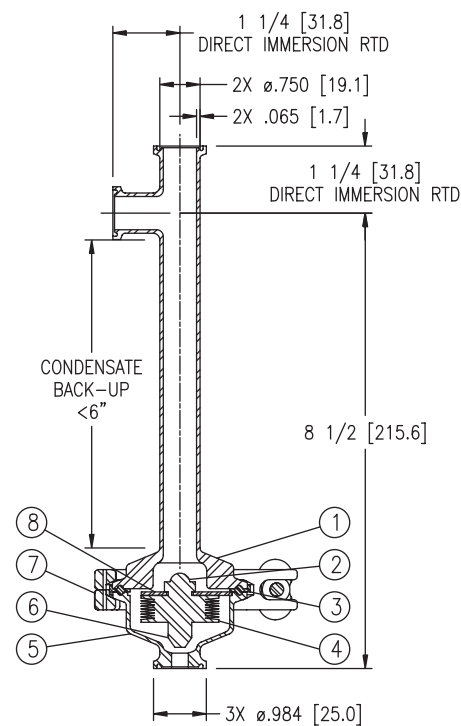

CME-A Direct Immersion RTD  
2.3 lbs

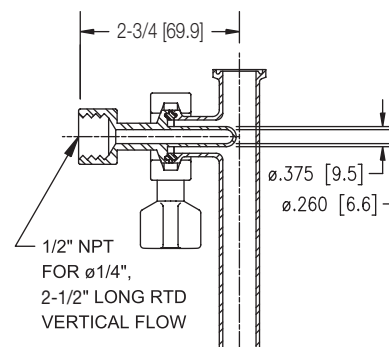

CME-W25 Vertical Flow  
2.8 lbs

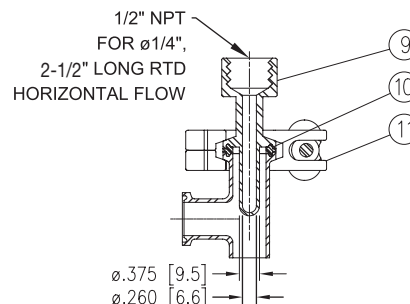

CME-W25 Horizontal Flow

Connections: 3/4" Hygienic Clamp



## CDS SANITARY THERMOSTATIC STEAM TRAPS

Pressures to 100 PSIG (6.9 barg)  
Temperatures to 338°F (170°C)

**Steepest Interior Surfaces**—Designed to completely drain without puddling.

**Stainless Steel Body**—Body Material is 316L Stainless Steel with 20  $\mu$  in. (0.5  $\mu$ m) Ra internal finish and 32  $\mu$  in. (0.75  $\mu$ m) Ra external finish. Available with mechanical polishing to 10  $\mu$  in. (0.25  $\mu$ m) Ra and/or electropolish.

**Self centering Valve**—Leak tight shut off. Assembly of actuator and valve to impingement plate allows the valve to self align with center of the orifice.

**Temperature Sensitive Actuator**—One moving part. 316L Stainless Steel, fail open, welded actuator for maximum corrosion, thermal and hydraulic shock resistance.

**Directional Discharge**—Erosion prevented by directing discharge to center of piping.

**Maintenance**—Can be easily removed and disassembled for sterilization and/or repair.

**Three Year Guarantee**—Guaranteed for three years against defects in material or workmanship.

**Industry Standard Food Grade Gasket**—White Viton food grade gasket offers superior performance for higher pressure steam applications.

**Large Orifice Selection**—Broad selection of orifice sizes provide greatest sizing and selection flexibility.

**Superior Air Handling**—Best air handling capability provides for fast startup.

**Unique SLR Orifice Option**—Specify when immediate elimination of condensate and improved sensitivity is desired. An orifice on the valve allows for continuous discharge of condensate. Trap will nominally pass 50 lb/hr (22.7 kg/hr) of condensate at 50 psi (3.4 barg) within 0.5°C (1°F) of saturated temperature.

**Bar Stock**—Connection fittings are not welded onto inlet and outlet pieces.

### APPLICATIONS

- CIP/SIP System Condensate Drainage
- Sterilization of Process Vessels
- Culinary Steam
- Humidifiers
- WFI System Sterilization
- Fermenter Sterilization

### OPTIONS

- -B Bellows for low subcool
- MP - Mechanical Polish to 10  $\mu$  in. (0.25  $\mu$ m) Ra
- EP - Electropolish
- SLR - SLR Orifice
- Tef-Steel, PTFE, Teflon®, E.P.D.M., USP Class VI & other gasket materials available
- 6" Condensate Leg (CME-W25, CME-A)

### APPLICABLE CODES

- ASME BPE

Canadian Registration # 0E0591.9

### OPERATION

Thermal actuator is filled at its free length with a liquid having a lower boiling point than water. On start-up, valve is normally open to discharge air, non-condensibles and condensate. When steam enters trap, thermal actuator fill vaporizes to a pressure higher than line pressure. This forces valve

into seat orifice to prevent any further flow. As condensate collects, it takes heat from the actuator, lowering internal pressure. Line pressure will then compress thermal actuator to open valve and discharge condensate. Valve opening automatically adjusts to load conditions from minimum on very light loads to full lift at maximum load.

### MODELS

- CDS202—Low capacity
- CDS203—Medium capacity
- CDS204—High capacity

NOTE: Please specify if Material Test Reports (MTR) or Certificates of Conformance (COC) are required.

# CDS SANITARY THERMOSTATIC STEAM TRAPS

## SPECIFICATION

Steam trap shall be of balanced pressure design with 316L welded bellows capable of releasing condensate within 1°C (2-3°F) or 5°C (10°F) of saturated pressure. All other interior wetted components shall be of 316L stainless. It shall have interior body finish of at least 20 µ in. (0.5 µm) Ra and exterior body finish of at least 32 µ in. (0.75 µm) Ra. Trap shall utilize hygienic body clamp allowing disassembly for inspection or cleaning and be entirely self draining when installed in vertical configuration. Trap end connections shall be standard hygienic clamp. Thermostatic actuator shall employ a conical valve lapped to the seat. A minimum of three orifices shall be available. Traps shall have SLR orifice where drainage at saturated temperatures is required. Traps shall be guaranteed against defects for 3 years.

### MAXIMUM OPERATING CONDITIONS

PMO: Max. Operating Pressure	100 psig (6.9 barg)
TMO: Max. Operating Temperature	338°F (170°C)
PMA: Max. Allowable Pressure	150 psig (10.3 barg)
TMA: Max. Allowable Temperature	366°F (186°C)

### BODY SURFACE FINISH

Internal <20 µ in. (0.51 µm) Ra (SFC1). External <32 µ in. (0.75 µm) Ra. Optional mechanical polishing to 10 µ in. (0.25 µm) Ra and/or electropolish (SFC4)

### GASKET APPROVALS

FDA CFR Title 21 Part 177, USDA, USP Class VI, 3A Sanitary Standard, NSF

### SERVICE NOTES

Trap is designed to be self draining for vertical installation (discharge down)  
 1/2" - 3/4" service trap should be installed with 3/4" inlet gasket.  
 1" - 1 1/2" service trap should be installed with 1 1/2" inlet gasket.

### SLR ORIFICE OPTION

Specify when immediate elimination of condensate and improved sensitivity is desired. An orifice on the valve allows for continuous discharge of condensate. Trap will nominally pass 50 lb/hr (22.7 kg/hr) of condensate at 50 psi (3.4 barg) within 0.5°C (1°F) of saturated temperature.

### POLISHING PROCEDURE

All surface finishes are achieved without the use of additional buffing, compounds or grit.

### -B BELLOWS

1°C (2-3°F) subcool for sensitive applications under 40 psi (2.7 barg)

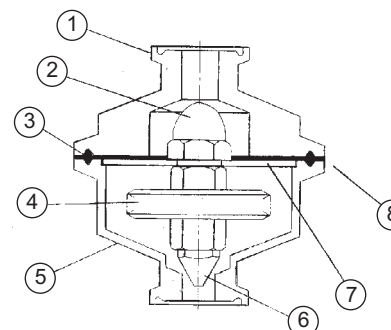
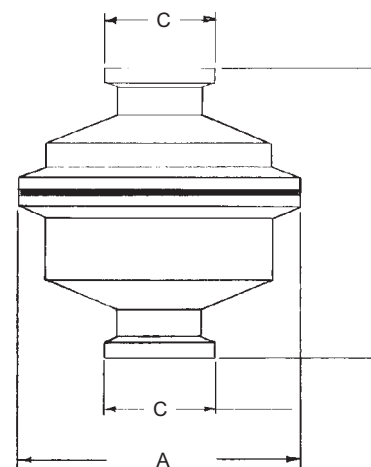

**Connections:**  
 1/2" – 1 1/2" Hygienic Clamp

DIMENSIONS inches (mm) and WEIGHTS pounds (kg)

Service	A	B	C	Weight
1/2 and 3/4	2 1/2 (63)	2 5/8 (67)	6 3/4 (25)	1.8 (.8)
1 and 1 1/2	2 1/2 (63)	2 5/8 (67)	1 6 3/4 (50)	2.3 (1.0)

### MATERIALS OF CONSTRUCTION

Item	Part Name	Material
1	Body – Inlet	316L A276
2	Actuator Nut	316L
3	Gasket	Viton 3227
4	Actuator	316L
5	Body – Outlet	316L A276
6	Valve	316L
7	Clamp (not shown)	304
8	Impingement Plate	316L

NOTE: Please specify if Material Test Reports (MTR) or Certificates of Conformance (COC) are required.

Maximum Capacity—lbs/hr 10°F Below Saturation (Kg/hr 5°C Below Saturation)		Differential PSIG (bar)										
Trap	Orifice Inches	5	10	20	30	40	50	60	70	80	90	100
		(0.34)	(0.7)	(1.4)	(2.1)	(2.8)	(3.4)	(4.2)	(4.9)	(5.6)	(6.2)	(6.9)
CDS 202	5/32	291 (132)	411 (186)	581 (264)	719 (326)	831 (377)	919 (417)	1000 (454)	1075 (488)	1130 (513)	1174 (533)	1207 (547)
CDS 203	1/4	550 (249)	825 (374)	1210 (549)	1495 (678)	1750 (794)	1975 (896)	2175 (987)	2350 (1066)	2525 (1145)	2650 (1202)	2825 (1281)
CDS 204	5/16	1520 (689)	1671 (758)	1869 (848)	2128 (965)	2301 (1044)	2509 (1138)	2713 (1230)	2819 (1278)	2946 (1336)	3091 (1402)	3159 (1433)

For Kg/Hr Multiply by .454



### APPLICATIONS

- CIP/SIP System Condensate Drainage
- Sterilization of Process Vessels
- Culinary Steam
- Humidifiers
- WFI System Sterilization
- Fermenter Sterilization

### OPTIONS

- -B Bellows for low subcool
- MP - Mechanical Polish to 10  $\mu$  in. (0.25  $\mu$ m) Ra
- EP - Electropolish
- SLR - SLR Orifice
- Tef-Steel, PTFE, Teflon®, E.P.D.M., and other gasket materials available
- CoMBo inlet available
- Specify 1/4" or 5/16" orifice

### APPLICABLE CODES

- ASME BPE

Canadian Registration # 0E0591.9C

### OPERATION

Thermal actuator is filled at its free length with a liquid having a lower boiling point than water. On start-up, valve is normally open to discharge air, non-condensibles and condensate. When steam enters trap, thermal actuator fill vaporizes to a pressure higher than line pressure. This forces valve

# CDH SANITARY THERMOSTATIC STEAM TRAPS

Pressures To 100 PSIG (6.9 barg)  
Temperatures to 338°F (170°C)

**Universally Configurable**—Horizontal connections from any direction on standard model; AI and AO models feature one multi-directional horizontal and one vertical connection. The CoMBo condensate measuring elbow can be installed as the inlet to this trap (-B bellows required).

**Steepest Interior Surfaces**—Designed to completely drain without puddling, even in significantly sloped lines.

**Stainless Steel Body**—Body Material is 316L Stainless Steel with 20  $\mu$  in. (0.5  $\mu$ m) Ra internal finish and 32  $\mu$  in. (0.75  $\mu$ m) Ra external finish. Available with mechanical polishing to 10  $\mu$  in. (0.25  $\mu$ m) Ra and/or electropolish.

**Self centering Valve**—Leak tight shut off. Assembly of actuator and valve to impingement plate allows the valve to self align with center of the orifice.

**Temperature Sensitive Actuator**—One moving part. 316L Stainless Steel, fail open, welded actuator for maximum corrosion, thermal and hydraulic shock resistance.

**One Size Suits Most Services**—Universal hygienic clamp fits both 1/2" and 3/4" piping.

**Maintenance**—Can be easily removed and disassembled for sterilization and/or repair.

**Four Year Guarantee**—Guaranteed for four years against defects in material or workmanship.

**Inventory Standard Food Grade Gasket**—White Viton food grade gasket offers superior performance for higher pressure steam applications.

**Superior Air Handling**—Best air handling capability provides for fast startup.

**Unique SLR Orifice Option**—Specify when immediate elimination of condensate and improved sensitivity is desired. An orifice on the valve allows for continuous discharge of condensate. Trap will nominally pass 50 lb/hr (22.7 kg/hr) of condensate at 50 psi (3.4 barg) within 0.5°C (1°F) of saturated temperature.

**Bar Stock**—Connection fittings are not welded onto inlet and outlet pieces.

### MODELS

- CDH-AI-AO—Horizontal inlet and outlet
- CDH-AI—Horizontal inlet, vertical outlet
- CDH-AO—Vertical inlet, horizontal outlet

NOTE: Please specify if Material Test Reports (MTR) or Certificates of Conformance (COC) are required.

into seat orifice to prevent any further flow. As condensate collects, it takes heat from the actuator, lowering internal pressure. Line pressure will then compress thermal actuator to open valve and discharge condensate. Valve opening automatically adjusts to load conditions from minimum on very light loads to full lift at maximum load.

# CDH SANITARY THERMOSTATIC STEAM TRAPS

## SPECIFICATION

Steam trap shall be of balanced pressure design with 316L welded bellows capable of releasing condensate within 5°C (10°F) of saturated pressure. All other interior wetted components shall be of 316L stainless. It shall have interior body finish of at least 20 µ in. (0.5 µm) Ra and exterior body finish of at least 32 µ in. (0.75 µm) Ra. Trap shall utilize hygienic body clamp allowing disassembly for inspection or cleaning and be entirely self draining in horizontal or angle piping configuration. Trap end connections shall be standard hygienic clamp. Thermostatic actuator shall employ a conical valve lapped to the seat. Traps shall have SLR orifice where drainage at saturated temperatures is required. Traps shall be guaranteed against defects for four years.

### MAXIMUM OPERATING CONDITIONS

PMO: Max. Operating Pressure	100 psig (6.9 barg)
TMO: Max. Operating Temperature	338°F (170°C)
PMA: Max. Allowable Pressure	150 psig (10.3 barg)
TMA: Max. Allowable Temperature	366°F (186°C)

### MATERIALS OF CONSTRUCTION

Part #	Part Name	Material
1	Body – Inlet .....	A276 316L
2	Clamp .....	304
3	Gasket .....	Viton 3227
4	Body – Outlet .....	A276 316L
5	Actuator Nut .....	316L
6	Impingement Plate .....	316L
7	Actuator .....	316L SS
8	Valve .....	316L

### BODY SURFACE FINISH:

Internal <20 µ in. (0.5 µm) Ra SFCI. External <32 µ in. (0.75 µm) Ra. Optional mechanical polishing to 10 µ in. (0.25 µm) Ra and/or electropolish SFC4

### GASKET APPROVALS:

FDA, USDA, USP Class VI, 3A Sanitary Standard, NSF

### SLR ORIFICE OPTION

Specify when immediate elimination of condensate and improved sensitivity is desired. An orifice on the valve allows for continuous discharge of condensate. Trap will nominally pass 50 lb/hr (22.7 kg/hr) of condensate at 50 psi (3.4 barg) within 0.5°C (1°F) of saturated temperature.

### POLISHING PROCEDURE

All surface finishes are achieved without the use of additional buffing, compounds or grit.

### -B BELLOWS

Maximum Capacity—lbs/hr 10°F Below Saturation (Kg/hr 5°C Below Saturation)		Differential PSIG (bar)										
Trap	Orifice Inches	5 (0.34)	10 (0.7)	20 (1.4)	30 (2.1)	40 (2.8)	50 (3.4)	60 (4.2)	70 (4.9)	80 (5.6)	90 (6.2)	100 (6.9)
CDH	1/4	550 (249)	825 (374)	1210 (549)	1495 (678)	1750 (794)	1975 (896)	2175 (987)	2350 (1066)	2525 (1145)	2650 (1202)	2825 (1281)
	5/16	1520 (689)	1671 (758)	1869 (848)	2128 (965)	2301 (1044)	2509 (1138)	2713 (1230)	2819 (1278)	2946 (1336)	3091 (1402)	3159 (1433)

For Kg/Hr Multiply by .454

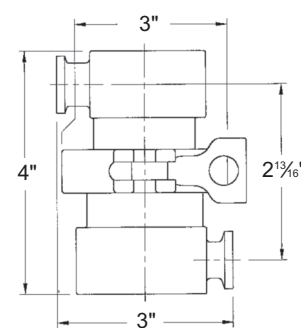

CDH-AI-AO – 3.9 LB. (1.8 kg)

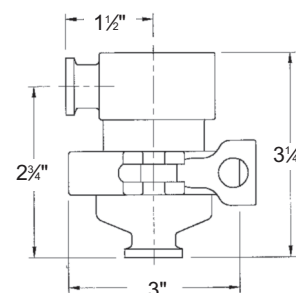

CDH-AI – 2.6 LB. (1.2 kg)

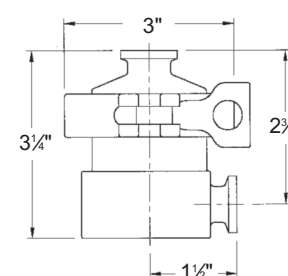

CDH-AO – 3.1 LB. (1.4 kg)

**Connections:**  
1/2/3/4" Hygienic Clamp

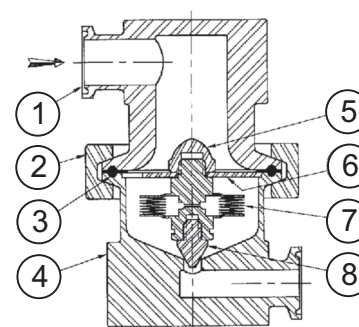

U.S. PATENT NO. 6,220,519

8

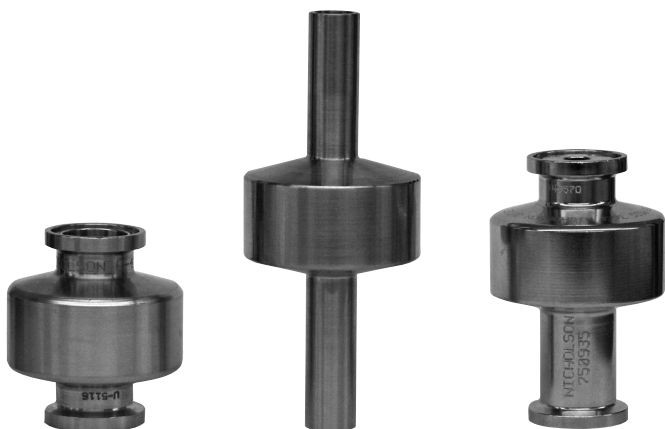

## DS100/DS110 THERMOSTATIC STEAM TRAPS

Pressures To 150 PSIG (10.3 barg)  
Temperatures to 366°F (186°C)

**Stainless Steel Body**—Body materials of all models are Type 316L Stainless Steel.

**Self Centering Valve**—Leak tight shut off. Assembly of actuator and valve to impingement plate allows valve to self-align with center of valve seat orifice. Provides long lasting valve and seat.

**Temperature Sensitive Actuator**—316L Stainless welded actuator for maximum corrosion, thermal and hydraulic shock resistance. One moving part.

**Thermal and Hydraulic Shock Resistant**—Impingement plate plus welded construction prevents damage to actuator.

**Long Life Valve and Seat**—Stainless steel valve and seat matched together for water tight seal.

**Maintenance**—All models are sealed and maintenance free.

**Directional Discharge**—Erosion prevented by directing discharge into the center of pipe or tubing.

**Best Air Handling Capacity**—Fast start up and operation.

**Fast Response**—Quickly adjusts to condensate load or temperature changes.

**One Size Suits Most Services**—Universal hygienic clamp fits both 1/2" and 3/4" piping.

**Two Year Guarantee**—Trap guaranteed for two years against defects in material or workmanship.

### APPLICATIONS

- CIP/SIP System Condensate Drainage
- Sterilization of Process Vessels
- Culinary Steam
- Humidifiers
- WFI System Sterilization
- Main Drips

### APPLICABLE CODES

- ASME BPE

Canadian Registration # 0E0591.9C

### MODELS

- DS100—Hygienic Clamp end 1 $\frac{1}{8}$ " OAL
- DS100TE—Tube end
- DS110—Hygienic Clamp end 2 $\frac{5}{8}$ " OAL

NOTE: Please specify if Material Test Reports (MTR) or Certificates of Conformance (COC) are required.

### OPERATION

Thermal actuator is filled at its free length with a liquid having a lower boiling point than water. On start-up, valve is normally open to discharge air, non-condensibles and condensate. When steam enters trap, thermal actuator fill vaporizes to a pressure higher than line pressure. This forces valve

into seat orifice to prevent any further flow. As condensate collects, it takes heat from thermal actuator, lowering internal pressure. Line pressure will then compress thermal actuator to open valve and discharge condensate. Valve opening automatically adjusts to load conditions from minimum on very light loads to full lift at maximum load.

# DS100/DS110 THERMOSTATIC STEAM TRAPS

## SPECIFICATION

Steam trap shall be thermostatically actuated and maintenance free. Actuator shall be of single piece, fail open design consisting of 1.2" diameter, welded 316L stainless plates capable of releasing condensate within 5°C (10°F) of saturated pressure. Trap shall be constructed entirely of 316L stainless steel components with wetted body surfaces finished to 20 μ inch (0.5 μm) Ra or better. Trap shall be self draining when installed vertically in piping systems. Trap shall have tube or universal hygienic clamps. Ferruled connections shall be Tri-clamp compatible and designed to fit both 1/2" and 3/4" service. Trap shall be guaranteed against defects for 2 years.

### MAXIMUM OPERATING CONDITIONS

PMO: Max. Operating Pressure	150 psig	(10.3 barg)
TMO: Max. Operating Temperature	366°F	(170°C)
PMA: Max. Allowable Pressure	300 psig*	(20.7 barg)
TMA: Max. Allowable Temperature	500°F*	(260°C)

\*May be limited by rating of utilized end connection.

### MATERIALS OF CONSTRUCTION

Body- Inlet.....	A276 316L
Actuator.....	316L
Body - Outlet.....	IA276 316L
Valve.....	316L

### BODY SURFACE FINISH

Internal <20 μ in. (0.5 μm) Ra SFC1. External <32 μ in. (0.75 μm) Ra. Optional mechanical polishing to 10 μ in. (0.25 μm) Ra and/or electropolish SFC4

### SERVICE NOTES

Trap is designed to be self draining for vertical installation (discharge down). 1/2" - 3/4" ferrule service trap should be installed with 3/4" inlet gasket.

### SLR ORIFICE OPTION

Specify when immediate elimination of condensate and improved sensitivity is desired. An orifice on the valve allows for continuous discharge of condensate. Trap will nominally pass 50 lb/hr (22.7 kg/hr) of condensate at 50 psi (3.4 barg) within 0.5°C (1°F) of saturated temperature.

### CHECK VALVE OPTION

The DS110 can be provided with an in-line check valve, which replaces the standard tri-clamp gasket on the outlet of the trap. The body material is PTFE, the o-ring is FDA VITON and the spring is 316 SS. The cracking pressure is 0.125 PSI (+/- 15%). Contact factory for other check valve options.

Maximum Capacity—lbs/hr 10°F Below Saturation (Kg/hr 5°C Below Saturation)		Differential PSIG (bar)													
Trap	Orifice Inches	5	10	20	30	40	50	60	70	80	90	100	125	150	
		(0.34)	(0.7)	(1.4)	(2.1)	(2.8)	(3.4)	(4.2)	(4.9)	(5.6)	(6.2)	(6.9)	(8.62)	(10.3)	
DS100	1/4	550 (249)	825 (374)	1210 (549)	1495 (678)	1750 (794)	1975 (896)	2175 (987)	2350 (1066)	2525 (1145)	2650 (1202)	2825 (1281)	3140 (1424)	3425 (1554)	

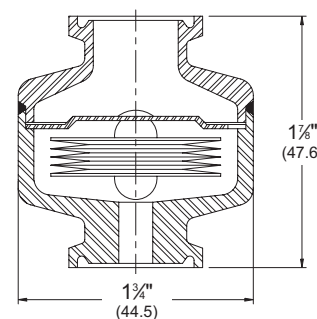

DS100 HYGIENIC CLAMP CONNECTION  
1/2" & 3/4"  
w eight .4 lbs (0.18)

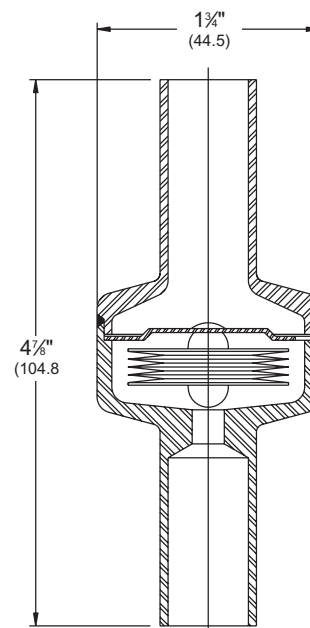

DS100TE TUBE CONNECTION  
(1/2" & 3/4")  
w eight .4 lbs (0.18)

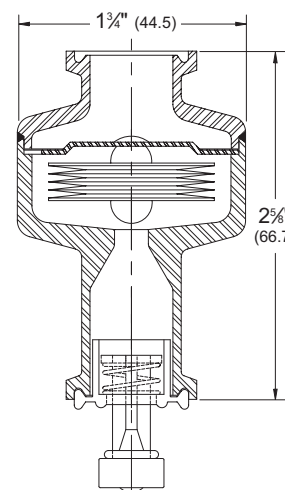

DS110 HYGIENIC CLAMP CONNECTION (3/4")  
w eight .4 lbs (0.18)  
Shown with optional Check Valve

Connections: 1/2" – 3/4" Tube



## DS200 SERIES THERMOSTATIC STEAM TRAPS

Pressures To 100 PSIG (6.9 barg)  
Temperatures to 338°F (170°C)

**Stainless Steel Body**—Body materials are Type 316L Stainless Steel.

**Self Centering Valve**—Leak tight shut off. Assembly of actuator and valve to impingement plate allows valve to self-align with center of valve seat orifice. Provides long lasting valve and seat.

**Temperature Sensitive Actuator**—One moving part. Inconel welded actuator for maximum corrosion, thermal and hydraulic shock resistance.

**Thermal and Hydraulic Shock Resistant**—Impingement plate plus welded construction prevents damage to actuator.

**Valve and Seat**—Long life, stainless steel valve and seat lapped and matched together for water tight seal.

**Maintenance**—All models are sealed and maintenance free.

**Three Year Guarantee**—Trap guaranteed for three years against defects in material or workmanship.

**Additional Features**—Best air handling capability for fast start up and operation. Fastest response to condensate load or temperature changes. Broad application range. Selection of orifice and pipe sizes meet majority of condensate removal demands in deionized steam systems.

**Unique SLR Orifice Option**—Specify when immediate elimination of condensate and improved sensitivity is desired. An orifice on the valve allows for continuous discharge of condensate. Trap will nominally pass 50 lb/hr (22.7 kg/hr) of condensate at 50 psi (3.4 barg) within 0.5°C (1°F) of saturated temperature.

### APPLICATIONS

- Platen Presses
- Plating Tanks
- Sterilizers
- Tire Presses
- Cooking Equipment
- Laundry Equipment
- Other Process Equipment

Canadian Registration # OE0591.9C

### MODELS

- DS202—Low capacity
- DS203—Medium capacity
- DS204—High capacity

### OPERATION

Thermal actuator is filled at its free length with a liquid having a lower boiling point than water. On start-up, valve is normally open to discharge air, non-condensibles and condensate. When steam enters trap, thermal actuator fill vaporizes to a pressure higher than line pressure. This forces valve

into seat orifice to prevent any further flow. As condensate collects, it takes heat from the actuator, lowering internal pressure. Line pressure will then compress thermal actuator to open valve and discharge condensate. Valve opening automatically adjusts to load conditions from minimum on very light loads to full lift at maximum load.

# DS200 SERIES THERMOSTATIC STEAM TRAPS

Steam trap shall be of balanced pressure design with 316L welded bellows capable of releasing condensate within 5°C (10°F) of saturated pressure. Where drainage at saturated temperatures is required, trap shall have SLR orifice. All other components shall be of 316 or 316L stainless steel. Trap shall be self draining and normally open.

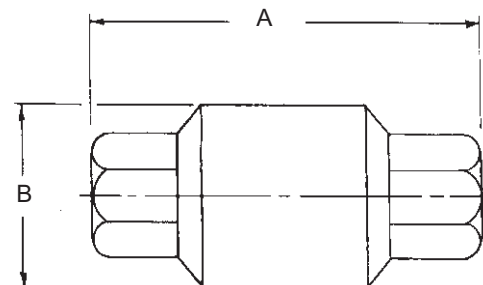

3/8" - 3/4" BODY

**Connections:**  
3/8" - 3/4" NPT or socketweld

## MAXIMUM OPERATING CONDITIONS

PMO: Max. Operating Pressure	100 psig	(6.9 barg)
TMO: Max. Operating Temperature	338°F	(170°C)
PMA: Max. Allowable Pressure	150 psig	(10.3 barg)
TMA: Max. Allowable Temperature	366°F	(186°C)

DIMENSIONS inches (mm) and WEIGHTS pounds

## MATERIALS OF CONSTRUCTION

Body.....ASTM A351 Grade CF3M (316L)  
Welded Actuator.....316L Fittings & Plates  
Valve & Seat.....316L Stainless Steel

NPT or Socket Weld	A	B	Weight
½ and ¾	3¾ (95)	1¾ (44)	1.1 (0.5)
¾	3⅞ (100)	1¾ (44)	1.2 (0.54)

## SLR ORIFICE OPTION

Specify when immediate elimination of condensate and improved sensitivity is desired. An orifice on the valve allows for continuous discharge of condensate. Trap will nominally pass 50 lb/hr (22.7 kg/hr) of condensate at 50 psi (3.4 barg) within 0.5°C (1°F) of saturated temperature.

Maximum Capacity—lbs/hr 10°F Below Saturation (Kg/hr 5°C Below Saturation)												
Trap	Orifice Inch (mm)	Differential PSIG (bar)										
		5 (0.34)	10 (0.7)	20 (1.4)	30 (2.1)	40 (2.8)	50 (3.4)	60 (4.2)	70 (4.9)	80 (5.6)	90 (6.2)	100 (6.9)
DS202	1/8 (3)	216 (98)	265 (120)	375 (170)	447 (203)	520 (236)	592 (269)	629 (285)	667 (302)	704 (319)	741 (336)	778 (353)
DS203	1/4 (6)	550 (249)	825 (374)	1210 (549)	1495 (678)	1750 (794)	1975 (896)	2175 (987)	2350 (1066)	2525 (1145)	2650 (1202)	2825 (1281)
DS204	5/16 (8)	860 (390)	1220 (554)	1725 (783)	2150 (975)	2475 (1123)	2725 (1237)	2940 (1334)	3125 (1417)	3290 (1492)	3450 (1565)	3575 (1622)



### APPLICATIONS

- Steam Tracing
- Drip Leg
- Heating
- Sanitary Applications

## SANITIZER NTD 230L SERIES SANITARY THERMODYNAMIC STEAM TRAPS

Pressures To 150 PSIG (10.3 barg)  
Temperatures to 850°F (454°C)

**Sanitary** — 316L stainless steel bar stock body, disc and cap, with surface finishes better than 32m in. Ra, prevent contamination and rouging.

**Compact Design** — Stainless steel disc is the only moving part.

**Inexpensive** — Low initial cost is less expensive than repairable technologies.

**Simplifies Installation** — Works in any position.

**Rugged** — Handles water hammer and superheat.

**Reliable, Efficient Operation** — Blast discharge quickly draws condensate and helps maintain system temperature.

**Freeze resistant** — Self draining design with vertical install drain prevents freezing.

**All 316L Stainless Steel Construction** — Resists both internal and external corrosion.

**Easy to Monitor** — Audible discharge cycle makes checking operation simple.

### MODELS

- NTD 230L–Sanitizer Thermodynamic Steam Trap

NOTE: Please specify if Material Test Reports (MTR) or Certificates of Conformance (COC) are required.

### OPERATION

Incoming air and condensate flow through the trap body and into the control chamber. Line pressure raises the disc off the seat, allowing complete discharge. When flashing condensate enters the cartridge, flow velocity increases, creating low pressure underneath the disc. Flashing condensate at high velocity strikes the inside wall of the disc chamber and is deflected to the top of the disc,

causing a pressure buildup. The disc is forced down onto the seat by this pressure imbalance. The trap remains closed as flashed vapor in the control chamber keeps the disc seated. Pressure inside the cap is not lowered until the trapped flash vapor condenses due to body radiation. Condensing steam lowers the pressure above the disc. Disc is then lifted and the cycle repeated.

# SANITIZER NTD 230L SERIES SANITARY THERMODYNAMIC STEAM TRAPS

## SPECIFICATION

Steam Trap shall be of the thermodynamic design. Body shall be of 316L stainless steel construction. Surface finishes shall exceed 32 µ in. (0.75 µm) grade. Trap body shall contain an integral seat. Cover shall seal to body without gaskets or seals. Trap shall be suitable for pressures through 150 PSI (10.3 barg). Trap end connections shall be hygienic clamp and accommodate mating connection sizes of 1/2 and 3/4 inch. Trap shall function installed in any pipe configuration.

### MAXIMUM OPERATING CONDITIONS

PMO: Max. Operating Pressure 150 psig (10.3 barg)  
 TMO: Max. Operating Temperature 850°F (454°C)  
 PMA: Max. Allowable Pressure 230 psig (15.9 barg)  
 TMA: Max. Allowable Temperature 850°F (454°C)

### MATERIALS OF CONSTRUCTION

Body.....316L Stainless Steel Bar Stock  
 Disc.....316L Stainless Steel Bar Stock  
 Cover.....316L Stainless Steel Bar Stock

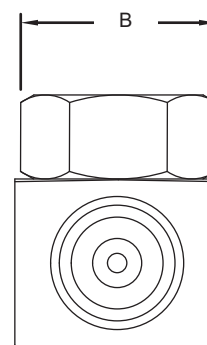
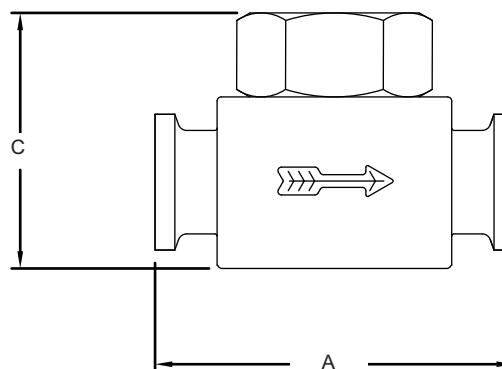

Connections: 1/2" / 3/4"  
Hygienic Clamp

DIMENSIONS inches (mm) and WEIGHTS pounds

A	B	C	Weight
2 3/8 (66)	1 1/2 (38)	2 (51)	1.31 (0.59)

Orifice	Maximum Capacity — lbs/hr (10°F Below Saturation)						
	Differential PSIG (barg)						
	5 (0.34)	10 (0.7)	20 (1.4)	50 (3.4)	100 (6.9)	125 (8.6)	150 (10.3)
0.141	215	236	264	345	447	486	521

For Kg/Hr Multiply by .454



STEAM SCRUBBER FILTER

#### APPLICATION DATA

- Culinary Grade Steam
- Sterilizers
- Autoclaves
- Pharmaceutical & Biotechnology Process Equipment
- Clean Room Humidification
- Chemical Industry
- Electronic Industry
- Plastic Industry

#### OPTIONS

- 316L Housing
- Silicone, Viton or Buna N Gaskets
- Flange or Welded Ends
- 4" to 8" with ANSI Flanged End

Canadian Registration #OE8186.80

**REQUIRES DRIP TRAP.  
COMBINE WITH DS200 TRAP  
FOR MOST CLEAN STEAM APPLICATIONS**

DS200 TRAP ON  
PAGE 10

# STEAM SCRUBBER STAINLESS STEEL FILTER

SIZES 1/2" to 3"  
PRESSURES to 145 PSIG at 353°F

**1 and 5 Micron Filters**—meet or exceed FDA guidelines and comply with 3A

**304 Stainless Steel Housing**—Electropolished and Passivated

**Double O-ring EPDM Housing Gasket**

**Inline NPT Connections**

**Single Clamp Closure**

**Sintered 316 Stainless Steel Filter Media**

**Porosity Level**—greater than 50%

**Filter Media**—in 1, 5 or 25 Micron Absolute Ratings

**Filter Element Endcaps**—304 Stainless Steel

**Renewable Filter Media**

**Single Open End Filter Media**

#### MODELS

- SS2L—2" low capacity
- SS3L—3" low capacity
- SS12—1/2" standard capacity
- SS34—3/4" standard capacity
- SS1—1" standard capacity
- SS114—11/4" standard capacity
- SS112—11/2" standard capacity
- SS2—2" standard capacity
- SS212—21/2" standard capacity
- SS3—3" standard capacity

NOTE: Please specify if Material Test Reports (MTR) or Certificates of Conformance (COC) are required.

# STEAM SCRUBBER STAINLESS STEEL FILTER

## SPECIFICATION

Furnish and install as shown on the plans, high efficiency, inline horizontal, filter for air, steam or gas constructed with 304 or 316L stainless steel housing and single, open ended element. Filter shall have an absolute rating of 1, 5 or 25 microns and utilize double o-ring gaskets to reduce potential downstream leakage of unfiltered medium. External surface finish of filter housing shall be no less than 180 grit (25-35 Ra microinch) and joined utilizing a single clamp. Filter media shall be of sintered 316L stainless steel and be regenerable. 1 and 5 micron media shall conform to 3A sanitary standards for production of culinary steam and be USDA accepted. Connections shall be NPT, flanged ANSI 150 or welded.

## MAXIMUM OPERATING CONDITIONS\*

PMO: Max. Operating Pressure	145 psig (10 barg) Limit for Saturated Steam 125 psig (8.6 barg)
TMO: Max. Operating Temperature	353°F (178°C)
PMA: Max. Allowable Pressure	232 psig / 0-400°F (16 barg / 0-204°C)
TMA: Max. Allowable Temperature	400°F / 0-232 psig (204°C / 0-16 barg)

\*For differential pressures greater than 75 psig, consult factory.

## MATERIALS OF CONSTRUCTION

Body, Standard.....	304 Stainless Steel
Body, Optional.....	316L Stainless Steel
Clamp.....	304 Stainless Steel
Plug.....	304 Stainless Steel
Gasket, Standard.....	EPDM
Gasket, Optional.....	Silicone
Gasket, Optional.....	Viton
Gasket, Optional.....	Buna N
Filter Media.....	Sintered 316L SSteel
Filter End Caps.....	304 Stainless Steel

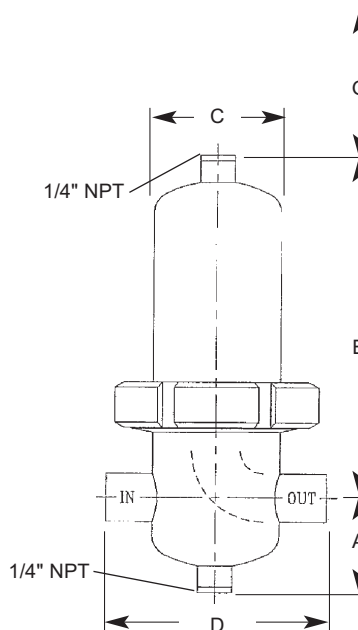

**Connections:**  
1/2" – 3" NPT, Flanged or Welded

DIMENSIONS inches (mm) and WEIGHTS pounds (kg)

Size	A	B	C	D	G	Weight	Conversion Factors (Cs)
1/2 (15)	2 1/8 (55)	7 3/8 (188)	2 3/4 (70)	4 1/8 (108)	3 3/4 (95)	4.2 (1.9)	0.17
3/4 (20)	2 1/8 (55)	8 3/8 (211)	2 3/4 (70)	4 7/8 (125)	6 (152)	4.4 (2.0)	0.25
1 (25)	2 7/8 (74)	8 3/8 (219)	3 3/8 (85)	4 7/8 (125)	6 (152)	5.7 (2.6)	0.39
1 1/4 (32)	2 7/8 (74)	10 5/8 (270)	3 3/8 (85)	5 1/2 (140)	8 (203)	6.6 (3)	0.50
1 1/2 (40)	3 3/4 (94)	11 1/2 (292)	4 1/8 (104)	6 5/8 (170)	8 (203)	10.1 (4.6)	0.67
2L* (50)	3 3/4 (94)	14 3/8 (366)	4 1/8 (104)	6 5/8 (170)	11 (279)	10.6 (4.8)	1.00
2 (50)	3 3/4 (94)	19 3/8 (493)	4 1/8 (104)	6 5/8 (170)	17 3/4 (451)	11.7 (5.3)	1.50
2 1/2 (65)	4 1/4 (106)	24 5/8 (626)	5 1/8 (129)	8 1/2 (216)	23 (584)	19.8 (9)	2.00
3L* (80)	4 1/4 (106)	34 5/8 (881)	5 1/8 (129)	8 1/2 (216)	33 1/2 (851)	23.8 (10.8)	2.70
3 (80)	4 5/8 (119)	35 3/4 (907)	6 (152)	9 3/8 (240)	33 1/2 (851)	35.6 (16.2)	4.00

Saturated Steam Capacity  
2"L, 250°F, 15 PSI (Cm)\*

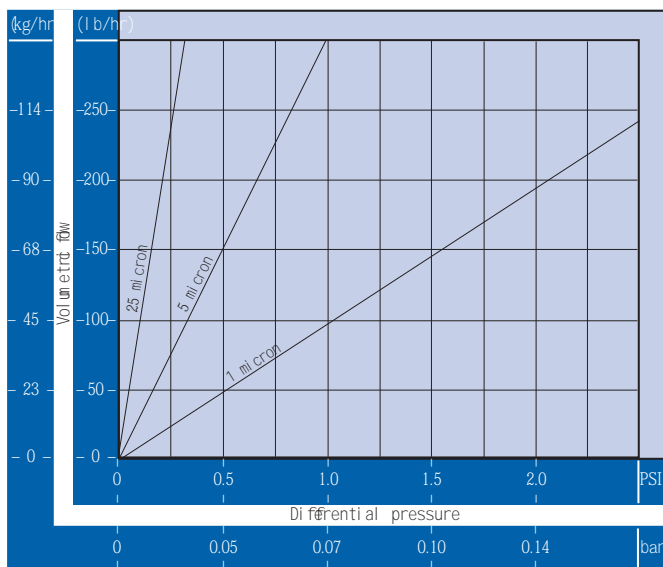

\*For other pressures and sizes, see conversion factors.

## SELECTION EXAMPLE

For optimum service life, the filter should have a 1 psi maximum pressure drop. Select a 5 micron filter for a flow rate of 110 lbs/hr (w) of saturated steam at 45 psi.

Where:  $Cs = \frac{w}{CmCp}$

Designing for .75 PSI differential pressure, Cm is 225 from the capacity chart and Cp is 2.0.

Therefore:  $Cs = \frac{110}{(225)(2.0)} = .24$  so 3/4" should be used.

Steam Pressure Conversion Factors (Cp)		PSI	0	15	30	45	60	75	90	105	120	135
Steam Pressure	PSI	0	1	2	3	4	5	6	7	8	9	
	bar	0	1	2	3	4	5	6	7	8	9	
Conversion factor		0.5	1.0	1.5	2.0	2.5	3.0	3.5	4.0	4.5	5.0	

## SANITARY STEAM TRAP SUMMARY

MODELS	CoMBo	CDS	CDH	DS100/DS110	NTD230L	DS200
SIZES (Inches)	1/2, 3/4	1/2, 3/4, 1, 1 1/2	1/2, 3/4	1/2, 3/4	1/2, 3/4	3/8, 1/2, 3/4
MAXIMUM PRESSURE (PSI)	40	100	100	150	150	100
SERVICEABLE	YES	YES	YES	NO	YES	NO
INTERNAL FINISH	SFC1	SFC1	SFC1	SFC1	< 32 $\mu$ In.	125
CONNECTIONS	HYGIENIC CLAMP	HYGIENIC CLAMP	HYGIENIC CLAMP	HYGIENIC & TUBE	HYGIENIC CLAMP	NPT
FLOW	VERTICAL & HORIZONTAL	VERTICAL	HORIZONTAL	VERTICAL	HORIZONTAL	VERTICAL
FREE DRAINING	YES	YES	YES	YES	NO	NO
ASME BPE COMPLIANT	YES	YES	YES	YES	NO	NO
OPTIONS	SLR	SLR	SLR	SLR		SLR
	MECHANICAL POLISH	MECHANICAL POLISH	MECHANICAL POLISH	MECHANICAL POLISH		
	SFC4	SFC4	SFC4	SFC4		
		-B BELLOWS	-B BELLOWS	CHECK VALVE		

All traps are exclusively 316L

SFC1 - <20  $\mu$  In.

SFC4 - Electropolish